

An intelligent Concentrated solar power plant based on Adaptive Neuro Fuzzy Interference System (ANFIS) trackers

HaniehSadat¹ Jannesari, Alireza Hajian²

¹ Msc. Graguated, Renewable Energies Engineering, Najafabad Branch, Islamic Azad University, Najafabad, Iran

^{2*} Associate professor, Department Physics, Najafabad Branch, Islamic Azad University, Najafabad, Iran (corresponding author)

Abstract¹: Concentrated solar plants consist of tracking systems to focus a large area of sunlight onto a small area. In this paper, a Fuzzy-Based Tracker System (FBTS) is presented using if-then fuzzy rules controller. The proposed FBTS is able to optimize the localization of the sun while also considering the availability of clouds and the wind direction to predict if there will be any shadow caused by the clouds in a part or the whole site area in which the group of lenses are installed. Having such a possibility will reduce the energy consumption in the step-per movement of the lens controller motor and at the same time prevent the wear of the rotating gears to find the best azimuth the related lenses. The test of Fuzzy-Sugeno model showed that the designed control system is robust to both sunny weather and clouds and has good flexibility on different days of the year.

Keywords: Concentrated solar power, Lense, Sugeno, Fuzzy logic, trackers

1.Introduction

Concentrated-solar technology systems use mirrors or lenses with tracking systems to focus a large area of sunlight onto a small area. The concentrated light is then used as heat or as a heat source for a conventional power plant (solar thermoelectricity) [1]. The solar concentrators used in CSP systems can often also be used to provide industrial process heating or cooling, such as in solar air conditioning [2]. As a sample of CSP , a modern CSP is illustrated in Fig.1.



Figure.1. Schematic airborne image of a modern Concentrated Solar Panel (CSP) [3], notice to the collector column in the center and thousands of mirrors around it.

Recent studies [3,4,5,6] are mostly focusing on the configuration of the mirrors in order to optimize the collected energy quantity while also pre-

tend to get the minimum risks for the environment.

One of the disadvantages of the available CSP's is the Dead warbler burned phenomena in mid-air by solar thermal power plant, in this study we replaced the mirrors by lenses to solve this problem, also the lenses controllers are based on a neuro-fuzzy system which helps to achieve a better optimized collection of solar energy during the day and reusing it at night hours.



Figure2. Dead warbler burned in mid-air by solar thermal power plant[3].

2. Mechanical design of sun tracker Lens

In this research, sun trackers were designed based on light collector lenses. Each of sun trackers contain two gears which enables it to have two degrees of freedom for the lens movement. Both gears are simultaneously rotating to put the lens in an optimal position relative to the apparent location of the sun in the sky so that it

receives the maximum intensity of sunlight at any given moment. The mechanical structure of the designed sun tracker is presented in figure 3 and the related parts with descriptions are listed in Table1.

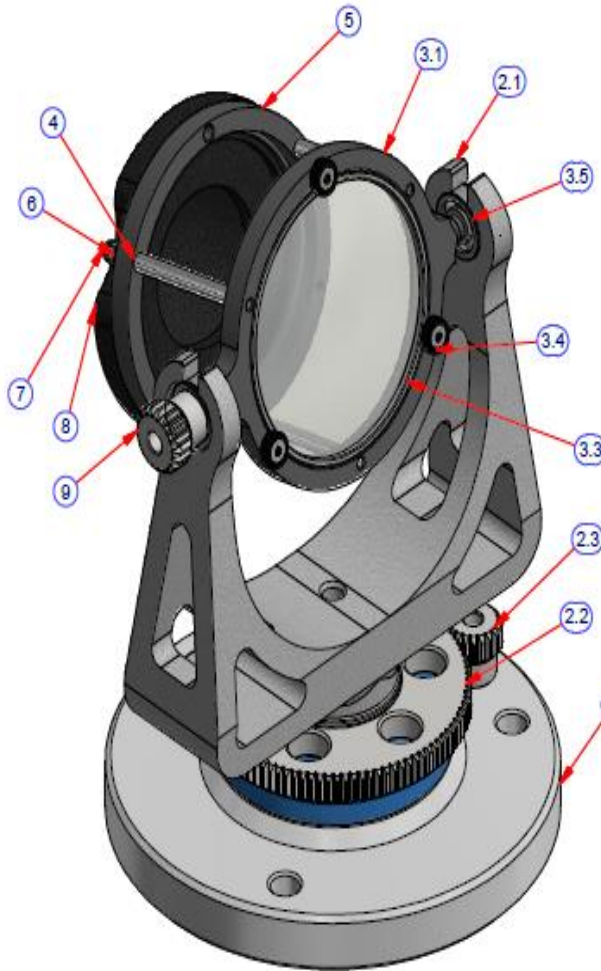

Figure3.3D view of Mechanical structure of the designed sun tracker lens (for description of the parts see Table1).

Table1. The list of mechanical parts of the designed sun tracker lens.

PARTS LIST			
ITEM	QTY	PART NUMBER	DESCRIPTION
1	1	Down Structure	
2	1	Main Structure	
2.1	1	Main Structure	
2.2	1	Spur Gear1	
2.3	1	Spur Gear2	
2.4	1	BS 290 SKF - SKF 6004-2RZ	Deep groove ball bearings single row
2.5	1	ANSI B 27.7M - 3AMI-20	
2.6	1	ANSI/B93.98M - 25x40x7	Rotary shaft lip type seals 2 - Metal cased
2.7	1	Down Structure-Cap	
3	1	Lens&Hoder	
3.1	1	Lens Holder	
3.2	1	Lens	
3.3	1	Lens Holder-Ring	
3.4	3	Clamp&Screw	
3.5	2	BS 290 SKF - SKF 627-2RZ	Deep groove ball bearings single row
4	3	Special Screw	
5	1	Support	
6	3	AS 1237 - 4	Flat metal washers for general
7	3	CNS 4473 - M 4	Hexagon Domed Cap Nuts
8	1	Concentrator	
9	1	Spur Gear21-2	

One of the challenges is the presence of clouds in the sky, if the location of the clouds in the sky. Because if the clouds cast a shadow on the lens, the intensity of the received light will decrease, so it is better to adjust the angle of the lens so that the least shadow of the clouds is placed on it. In this way , an intelligent Neuro-Fuzzy system was implemented in which the optimized angle of the lens is predicted not only based on both the time and date (the appearance location of the sun in the sky) but also the weather condition from the viewpoint of if it is cloudy and/or rainy. In the next section this neuro-fuzzy system is explained with more details.

3.Design of Adaptive Neuro-Fuzzy Interference System(ANFIS) for adjusting sun tracker

3.1.ANFIS concepts and mathematics

ANFIS approximates the functional relations between responses and input variables of the process under study by gradually fine-tuning the values of parameters. The ANFIS architecture with two inputs is shown in Figure 4.

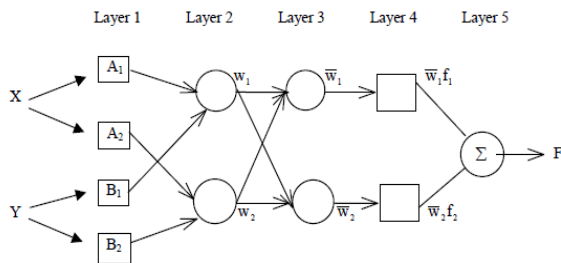

Figure4.Schematic diagram of an ANFIS structure with two inputs.

The circular nodes are fixed whereas the square nodes have parameters to be learnt. A Two Rule Sugeno ANFIS has rules of the form:

$$\text{If } x \text{ is } A_1 \text{ and } y \text{ is } B_1 \text{ THEN } f_1 = p_1 x + q_1 y + r_1 \quad (1)$$

$$\text{If } x \text{ is } A_2 \text{ and } y \text{ is } B_2 \text{ THEN } f_2 = p_2 x + q_2 y + r_2 \quad (2)$$

The final output of ANFIS is a weighted summation of f_1 and f_2 (see figure5).

For training the network, there is a forward pass which propagates the input vector through the network layer by layer and in the backward pass, the error is sent back through the

network in a similar manner to back propagation.

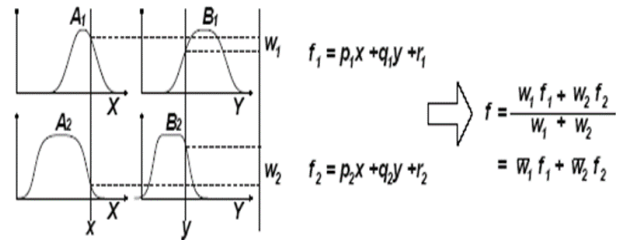

Figure5. Weighted summation of f_1 and f_2 in ANFIS to gain f as output.

3.2. Design of ANFIS for sun tracker lens controller

After the position of the sun in the sky was calculated for each moment of the day with a sampling rate of ten minutes for all days of the year 2020, we teach these solar positions to a neural-fuzzy network as training data until after training the neural network. Fuzzy controller is able to easily estimate the position of the sun in the sky with very high accuracy by receiving the exact date/time related to the longitude and latitude and the weather conditions from the view point of cloudy and rainy. The cloudy and rainy conditions are known based on online weather forecast applications very easily as are available in valid internet sites (Figure6).

The test of designed ANFIS error indexes are listed in Table2.The results showed that the intelligent sun tracker is suitable with the minimum errors indexes for a full 24 hours of the day when membership functions are Gaussian shaped, either in the days

light or at nights as it has a good ability to collect energy for night times.

Table2. Error indexes of designed ANFIS

MAPE(%)	R ²	NMSE	MSE	Membership function
2.979	0.90	0.05	0.00711	triangle
2.957	0.88	0.06	0.00707	Bell-shape
2.999	0.75	0.06	0.00719	trapezoidal
2.963	0.93	0.06	0.00702	Gaussian

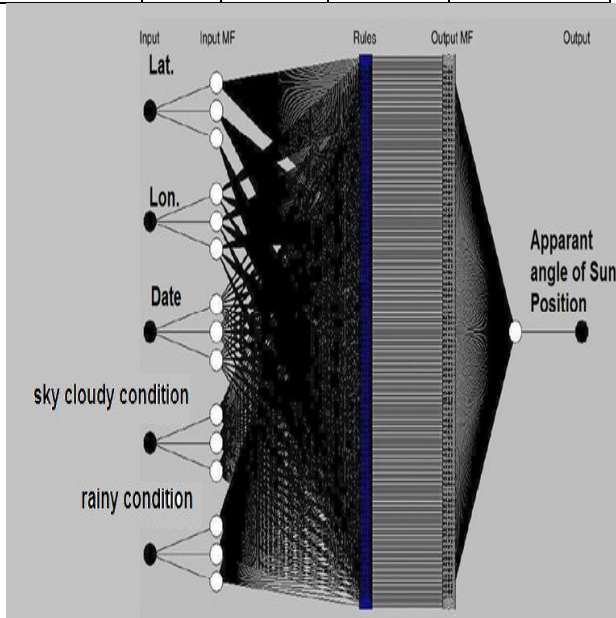

Figure.6. Structure of the ANFIS designed in this study to predict apparant angle of sun position

4. Conclusion

An intelligent CSP was presented based on adaptive neuro-fuzzy interference system to track the sun with lenses both in tight conditions of cloudy and rainy days.

The test of Fuzzy-Sugeno model showed that the designed control system is robust to both sunny weather and clouds and has good flexibility on different days of the year.

5. References

- [1] Mohamed El Chehaly, Power System Stability Analysis with a High Penetration of Distributed Generation, Thesis of Master, Department of Electrical and Computer Engineering, McGill University, Montréal, Québec, Canada February 2010.
- [2] C. Abbey, F. Katiraei, C. Brothers, L.ignard Bailey and G. Joos, "Integration of distributed generation and wind energy in Canada," in Proc. IEEE PES General Meeting 2006.
- [3] J. A. Lopes, N. Hatziargyriou, J. Mutale, P. Djapic and N. Jenkins, "Integrating distributed generation into electric power systems:A review of drivers, challenges and opportunities," *Electr. Power Syst. Res.*, vol. 77, pp. 1189-1203, 2007.
- [4] M. Rabinowitz, "Power systems of the future. 4," *IEEE Power Eng. Review*, vol .20 ,2000 ,pp. 4-9 .
- [5] Ontario Power Authority, "Inte-

grated Power System Plan " vol.
2011, pp. 34, August 29, 2008, 2008.
<http://www.powerauthority.on.ca/integrated-power-system-plan>
[6] V. Patel and M. Coble, The New

ERA in Distributed Generation: Delivering Resources to Every Corner of the World, Reinventing Energy, Section 2, 2018.