

Installation Requirements

for **SUNNY CENTRAL 200**



Contents

This document describes the dimensions, the minimum clearances to be observed, the quantities of supply and exhaust air required for smooth operation, and the cable routing. This Technical Information is valid for the Sunny Central 200.

1 Mechanical data

The Sunny Central 200 must be installed in an electrical equipment room. With the EVR (Extended Voltage Range) option, the maximum permissible DC voltage at the device connection in idle operation is increased to 1000 V_{DC}. As a result of EVR, more modules can be switched in series. This further reduces the work involved and hence also the installation costs of the photovoltaic generator. The EVR unit is mounted on top of the Sunny Central. If you are installing a Sunny Central with the combined options "Protection against chemically active environment" and EVR, the exhaust air is ducted out through the rear panel of the device.

1.1 Dimensions and Weight

A1: DC/inverter cabinet

A2: AC cabinet

B: Width

C1: Height with EVR

C2: Height without EVR

The DC/inverter cabinet and the AC cabinet are separate delivery items.

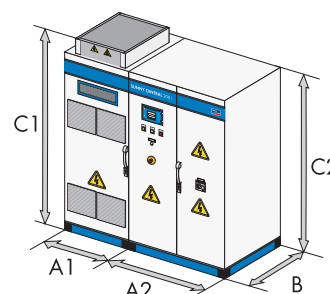

Dimensions

Length A1	Length A2	Width B	Height C1	Height C2
800* mm	1200 mm	800 mm	2310 mm	2100 mm

*For Sunny Central with option "Protection against chemically active substances", the length A1 is 1200 mm.

Weight

Weight A1	Weight A2*	Weight EVR	Total weight without EVR	Total weight with EVR
500 kg	1100 kg	50 kg	1600 kg	1650 kg

*For Sunny Central with option "Protection against chemically active substances", the weight of A2 is 1350 kg.

1.2 Minimum Clearances

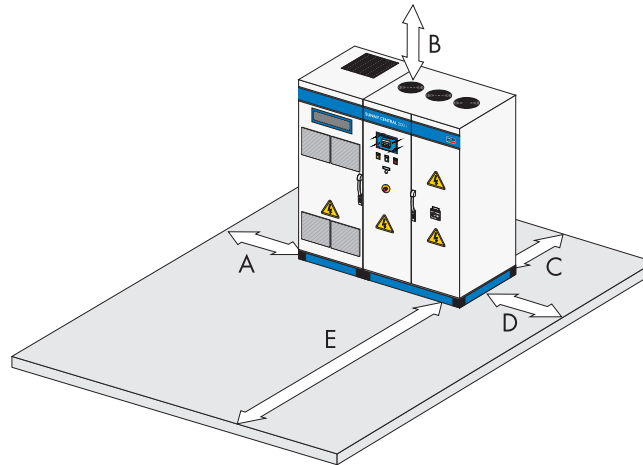

Regardless of the installation type, the following minimum clearances guarantee a smooth operation of the Sunny Central.

For type-specific installation work as well as for maintenance work, SMA recommends providing larger minimum clearances.

Installation without air duct

	A (mm)	B (mm)	C (mm)	D (mm)	E (mm)
Clearances for installation against a closed building wall with air exhaust through the rear panel	20	200	200	0	1100
Clearances with fan grill in building wall and air exhaust through the rear panel	20	200	50	0	1100
Clearances for air exhaust through top panel	20	400	10	0	1100

Installation with air duct

	A (mm)	B (mm)	C (mm)	D (mm)	E (mm)
Clearances for installation against a closed building wall with air exhaust through the rear panel	20	200	0	0	1100
Clearances with fan grill in building wall and air exhaust through the rear panel	20	200	0	0	1100
Clearances for air exhaust through top panel	20	0	0	0	1100

The minimum clearances B and C refer to the lower edge of the air duct. The length of the air duct depends on the project.

2 Ventilation

Air is supplied through the fan grills on the front side of the inverter. The exhaust air ducting is type-specific. It is either ducted through the rear panel or the top of the Sunny Central. When the EVR option is used, the exhaust air is always ducted through the rear panel.

The heated exhaust air generated by the inverter must be ducted away from the device so that the maximum permissible environmental temperature is not exceeded and / or the warm exhaust air does not unnecessarily heat the installation room. This will prevent thermal short-circuits. SMA recommends the on-site installation of an air exhaust system (e.g. air duct).

2.1 Air quality classification

Environmental requirements for stationary application	Class			
	3S1	3S2	3S3	3S4
a) Sand in the air [mg / m ³]	-	30	300	3000
b) Dust (suspended matter) [mg / m ³]	0.01	0.2	0.4	4.0
c) Dust (fallout) [mg / m ³]	0.4	1.5	15	40
Sites where appropriate measures are taken to keep dust levels to a minimum.	x	x	x	x
Sites where no special measures have been taken to reduce the sand or dust levels and which are not located in the vicinity of sand or dust sources.		x	x	x
Sites near sand and dust sources			x	x
Sites in production halls where sand or dust is present, or sites in geographical locations where the air is prone to high levels of sand and dust.				x

If the required air quality at the installation site of the Sunny Central is not available then on-site measures must be taken to satisfy these requirements (e.g. extra filters in the building air inlets etc.).

2.2 Air volume

For ventilation purposes, the DC/inverter switch cabinet complex is sub-divided into a DC cabinet and an inverter cabinet. The heat sink in the inverter cabinet has a separate ventilation system. Accordingly, different air quantities are required for each respective cabinet unit.

DC cabinet and inverter cabinet	AC cabinet	Total volume
1300 m ³ /h	2000 m ³ /h	3300 m ³ /h

2.3 Pressure reserves

The Sunny Central ventilating fans are designed with the following pressure reserves. These must be observed when the Sunny Central inverters are installed in an electrical equipment room where the exhaust air is discharged to the atmosphere through ventilation ducts.

DC cabinet and inverter cabinet	Power units	AC cabinet
none	80 Pa	none

The exhaust air from Sunny Central inverters installed in a station can in general be discharged to the atmosphere through a non-tapered air duct with a cross-section of up to 1 m. Additional pressure reserves are not available and must be executed on-site, for instance, by installing extra fans.

2.4 Optimum airflow in an electrical equipment room

Before a Sunny Central is installed in an electrical equipment room, on-site measures must be taken to ensure that supply air and exhaust air are ducted separately and that there is always an adequate supply of fresh air. The exhaust air from the power module at the rear of the Sunny Central must be discharged separately. If the indicated air pressure reserves of the individual cabinet ventilators are not sufficient, additional fans must be installed in the air duct.

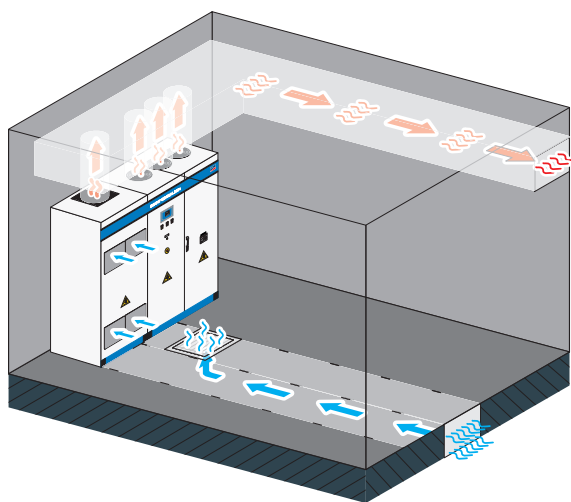

Exhaust air discharge through top panel

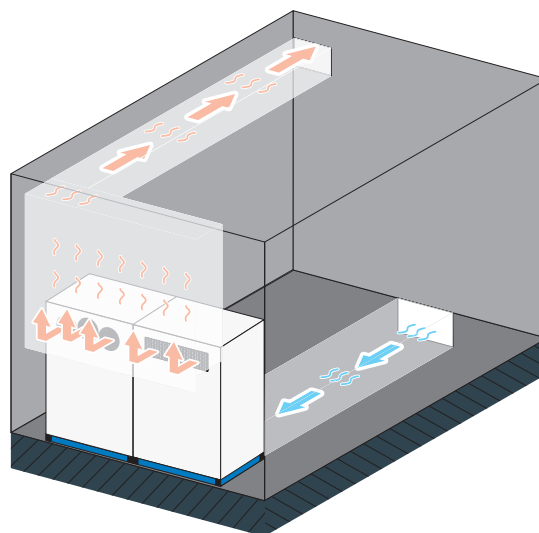

Exhaust air discharge through rear panel

The dimensioning of the ventilation ducts is carried out by an expert.

Ideally, the exhaust air from the power module is directly discharged to the atmosphere through an opening in the wall of the electrical equipment room.

2.5 Airflow in an electrical equipment room without air ducts

As a general rule, exhaust air must be extracted from the individual switch cabinets separately in order to avoid thermal short circuits. In exceptional cases the ventilation of Sunny Central inverters can be effected without ventilation ducts. In this case, it must be ensured that the electrical equipment room is sufficiently ventilated to discharge the exhaust air to the atmosphere.

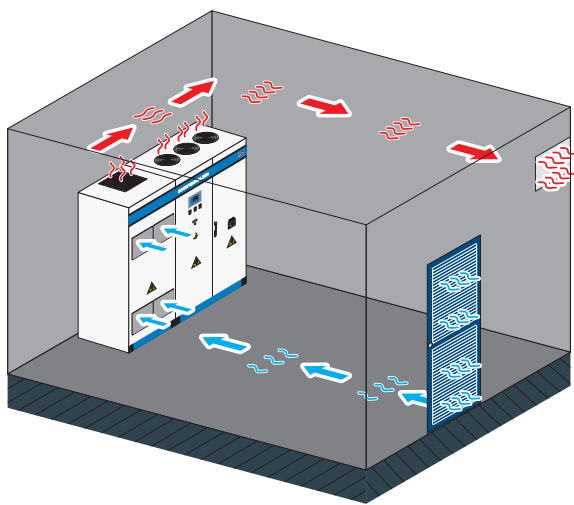

Exhaust air discharge through top panel

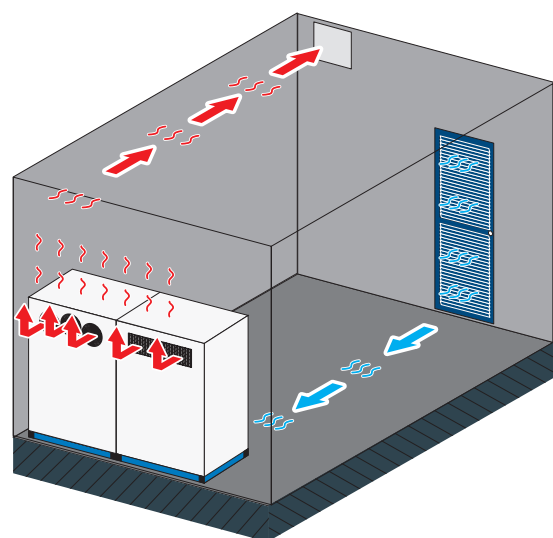

Exhaust air discharge through rear panel

SMA does not recommend this type of installation.

2.6 Dimensions of the exhaust vent in the rear panel

Standard

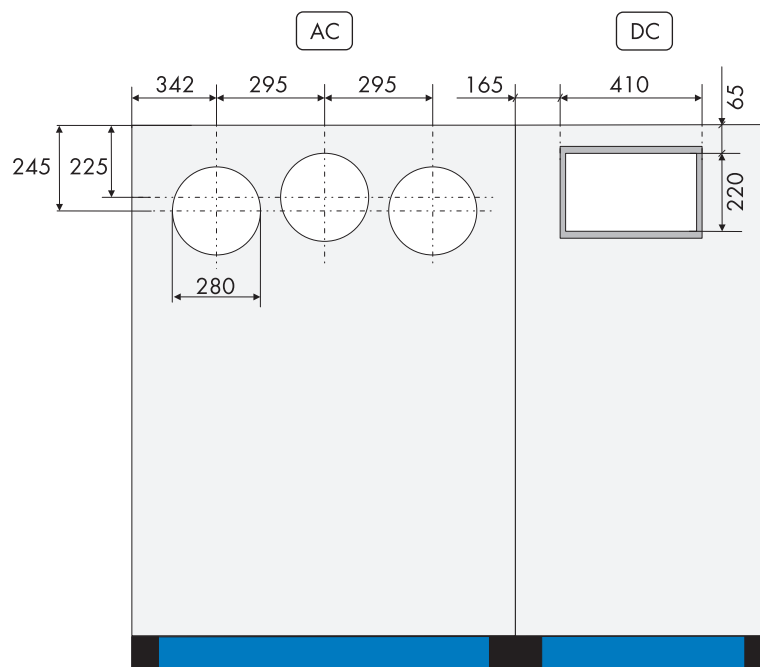

Option "Protection against chemically active substances"

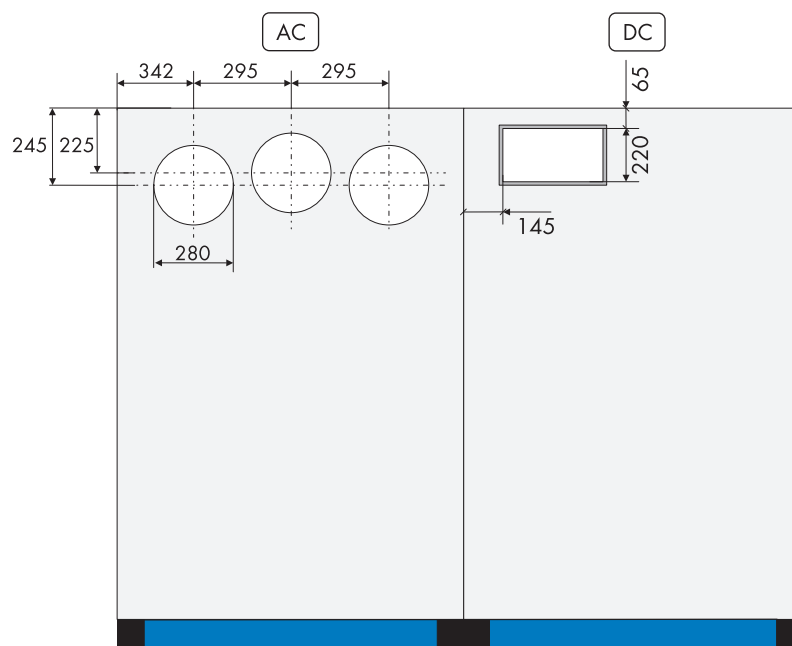

2.7 Dimensions of exhaust vents in the top panel

Standard

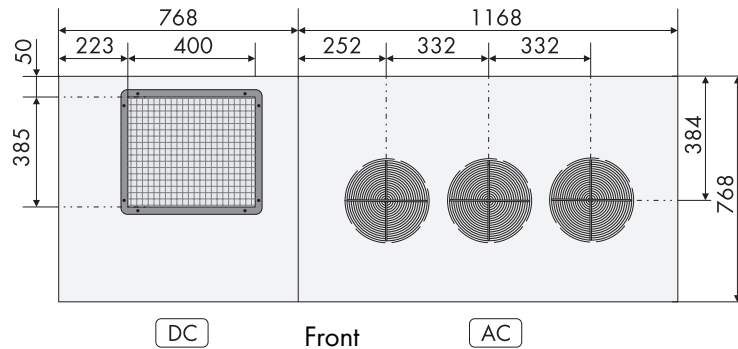

Option "Protection against chemically active substances"

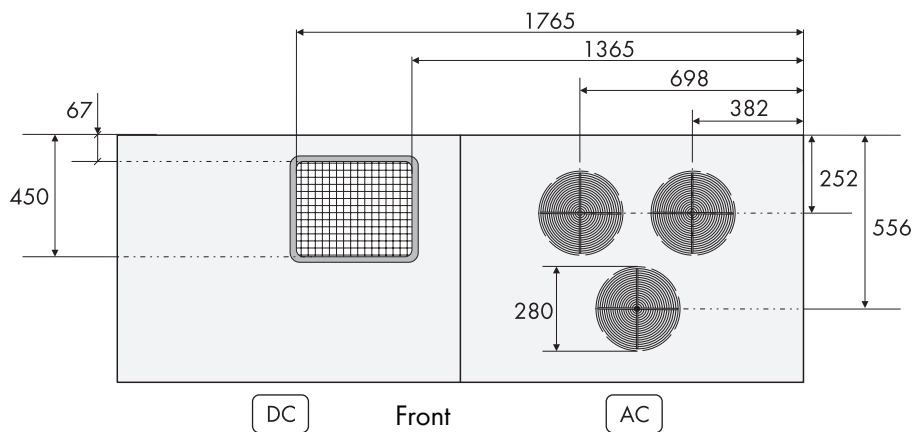

3 Power Cabling and Anchorage

The AC, DC, PE and communication cabling, as well as the internal supply of the Sunny Central is executed through the skirting and base plate. The connection terminals for the AC, communication and internal supply cables are located in the AC cabinet. The floor unit of the DC cabinet is made up of several sliding panels through which the DC and PE cabling is routed. All openings in the floor unit must be sealed. The following diagrams show the anchor points and cable apertures in the floor unit for AC, DC, PE and communication cabling. All measurements given in mm.

3.1 Floor apertures in standard version

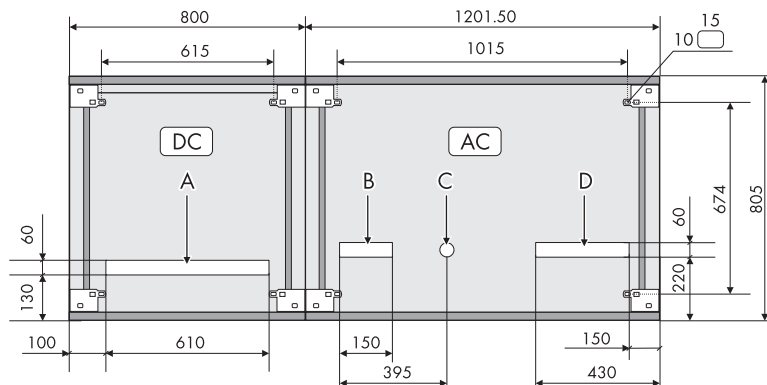

- A Opening for DC cable
- B Opening for signal and PE cables
- C Opening for Team cable (optional)
- D Opening for AC cable

3.2 Floor apertures in version "Protection against chemically active substances"

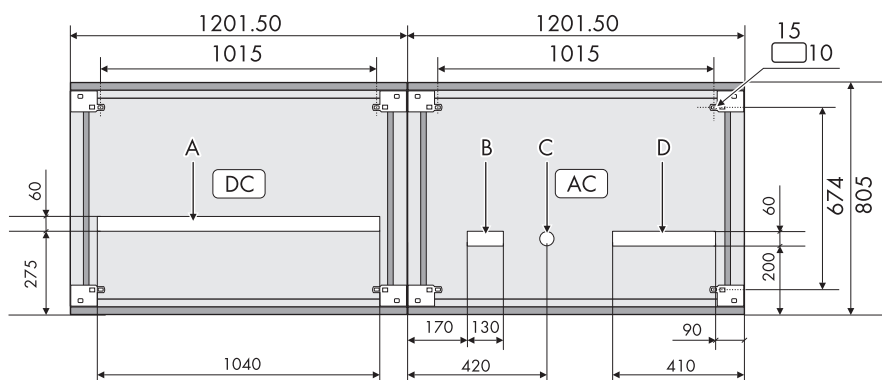

- A Opening for DC cable
- B Opening for signal and PE cables
- C Opening for Team cable (optional)
- D Opening for AC cable

4 Cable Cross-sections and Torques

4.1 DC Connection

DC fuses which enable the optional connection of Sunny String-Monitors are located in the Sunny Central DC cabinet. All Sunny Central inverters are equipped as standard with one busbar per potential.

Busbar

Cable lug	Max. cross-section	Torque
M12	240 mm ²	74 Nm

DC fuses

Cable lug	Max. cross-section	Torque
M10	240 mm ²	31 Nm

Connections of DC main distributors

When using a Sunny Central 200 with busbar, up to 5 Sunny Main Boxes can be connected in the DC connection area.

4.2 AC Connection

	Cable lug	Max. cross-section	Torque
Breaker	M12	240 mm ²	31 Nm
Terminal	M12	240 mm ²	31 Nm

The size of the cable must be adequate to take the maximum PV voltage and must have double or reinforced insulation.